

Numark PPD

Professional Disc Jockey Products

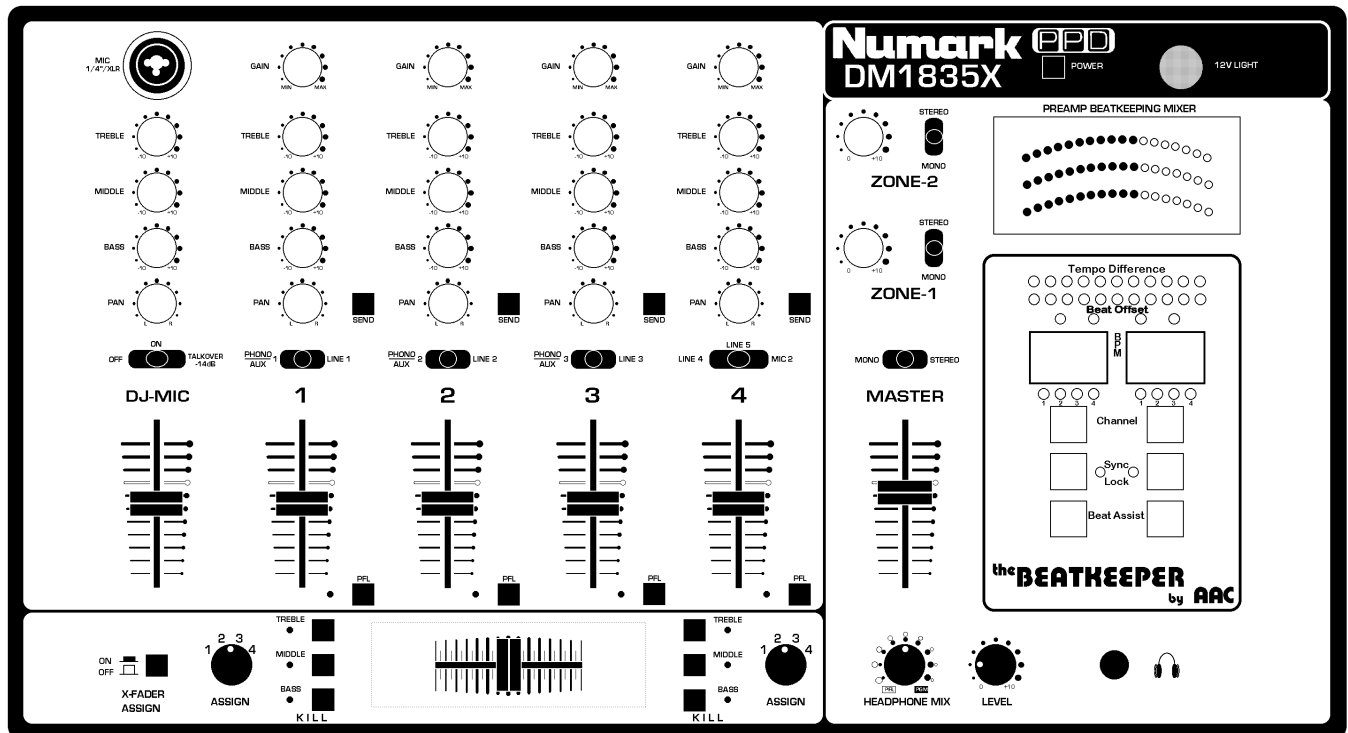

DM 1835X STEREO MIXER

OWNER'S MANUAL



Numark - The Proven Leader in DJ Technology

Safety Information and Product Registration

	CAUTION RISK OF ELECTRIC SHOCK DO NOT OPEN	
<p>CAUTION: TO REDUCE THE RISK OF ELECTRIC SHOCK DO NOT REMOVE ANY COVER. NO USER-SERVICEABLE PARTS INSIDE. REFER SERVICING TO QUALIFIED SERVICE PERSONNEL ONLY.</p> <p>The lightning flash with arrowhead symbol within the equilateral triangle is intended to alert the user to the presence of un-insulated "dangerous voltage" within the product's enclosure that may be of sufficient magnitude to constitute a risk of electric shock to persons.</p> <p>The exclamation point within the equilateral triangle is intended to alert the user to the presence of important operating and maintenance (servicing) instructions in the literature accompanying this appliance.</p>		

CAUTION
FOR USA & CANADIAN MODELS ONLY
TO PREVENT ELECTRIC SHOCK DO NOT USE THIS (POLARIZED) PLUG WITH AN EXTENSION CORD, RECEPTACLE OR OTHER OUTLET UNLESS THE BLADES CAN BE FULLY INSERTED TO PREVENT BLADE EXPOSURE.

SAFETY INSTRUCTIONS

1. Read Instructions - All the safety and operating instructions should be read before this product is connected and used.
2. Retain Instructions - The safety and operating instructions should be kept for future reference.
3. Heed Warnings - All warnings on this product and in these operating instructions should be followed.
4. Follow Instructions - All operating and other instructions should be followed.
5. Water and Moisture - This product should be kept away from direct contact with liquids.

6. Heat - Avoid placing this product too close to any high heat sources such as radiators.

7. Power Sources - This product should be connected to a power supply only of the type described in these operating instructions, or as marked on the unit.

8. Power Cord Protection - Power supply cords should be routed so that they are not likely to be walked upon or pinched by items placed on or against them. When removing the cord from a power outlet be sure to remove it by holding the plug attachment and not by pulling on the cord.

9. Object and Liquid Entry - Take care that objects do not fall into and that liquids are not spilled into the inside of the mixer.

10. Damage Requiring Service - This product should be serviced only by qualified personnel. If you have any questions about service please contact **Numark** at the number(s) shown on the back cover of this manual.

11. Grounding or Polarization - Precautions should be taken so that the grounding or polarization means built into the mixer is not defeated.

12. Internal/External Voltage Selectors - Internal or external voltage selector switches, if any, should only be reset and re-equipped with a proper plug for alternative voltage by a qualified service technician. Do not attempt to alter this yourself.

NOTE: This apparatus does not exceed the Class A/Class B (whichever is applicable) limits for radio noise emissions from digital apparatus as set out in the radio interference regulations of the Canadian Department of Communications.

WARNING: To reduce the risk of fire or electric shock, do not expose this appliance to rain or moisture. Electrical equipment should NEVER be kept or stored in damp environments.

Please record the serial number of your unit as shown on the back of the chassis as well as the name of the dealer from whom you purchased the unit. Retain this information for your records. Please return the warranty card enclosed to register your mixer with us.

MODEL: DM1835X	PURCHASED FROM: _____
SERIAL NUMBER: _____	DATE OF PURCHASE: _____

Numark - The Proven Leader in DJ Technology

NUMARK DM1835X STEREO MIXER

INDEX

Safety Information Product Registration	Page 3
Introduction and Features	Page 5
Precautions	Page 7
Front Panel Diagram	Page 8
Beatkeeper Diagram	Page 10
Beatkeeper Operation	Page 11
Rear Panel Diagram	Page 16
Connection Instructions and Diagram	Page 17
Specifications	Page 18
Block Diagram	Page 19
Warranty and Service	Page 20

CONGRATULATIONS!

You have purchased the **DM1835X** Stereo Mixer by **Numark**. This equipment features all new multi-source Beatkeeper technology. With all new circuitry and the latest in manufacturing and design technology you get greater quality and better reliability than ever before. The **DM1835X Preamp Mixer** has been designed by DJs for DJs. It gives you all of the controls and features you need in a professional piece of equipment to show off the best of your skills.

Thank you for buying Numark DJ products!

FEATURES...

- *User replaceable assignable ALPs™ crossfader .*
- *Bass, Mid, Treble, and Gain controls on every input channel.*
- *Left->Right Pan control on each channel and the DJ Mic.*
- *Bass, Mid & Treble “KILL” switches for special effects and creative mixing.*
- ***Neutrik™** “Combo” connector allows 1/4” or XLR plug to be used for DJ Mic.*
- *8 line inputs.*
- *Three phono inputs switchable to line level.*
- *Sends on each channel for easily hooking up external effects.*
- *Pushbutton Cueing with PFL (pre-fader listen) on each channel.*
- *Headphone monitoring with PFL/Program fader.*
- *Master and 2 Zone outputs.*
- *Stereo/Mono switch on the Master and Zones.*
- *Balanced Outputs.*
- *Tape Out for direct recording.*
- *Powerful stereo headphone output.*
- *High-end performance audio signal.*
- *12V BNC light connector.*

the **BEATKEEPER Features:**

- *Automatic BPM tracking of up to 8 input sources (4 simultaneously)*
- *Accurate digital BPM displays*
- *Visual live tracking of your mix progress, using Tempo Difference and Beat Offset Bar Graphs*
- ***All visual displays update on every beat***
- *Sync Lock Button for accurate BPM tracking*
- *Beat Assist for locking to the correct beat*
- *Simple user interface*

Once you've synced your Beatkeeper you've opened a whole new dimension in mixing. The Beatkeeper has two bar graphs - one showing the tempo difference, and the other showing the beat offset. Now you can see when your mix is on track. If the beats start to drift, you'll be able to easily adjust the music before your audience can hear it. No other beat counter or automatic mixer can give you the power to make a more accurate mix.

Numark - The Proven Leader in DJ Technology

**As a special bonus we have
included a right angle headphone
adapter with this mixer.
Just plug your headphones into
the adapter and then plug the
adapter into your mixer.**

IMPORTANT INFORMATION...

Please read this entire manual before connecting the DM1835X to your system.

For optimum performance:

- Always make sure that AC power is OFF while making any connections.
- Do not use excessively long cables (i.e. over 50ft/14m) Be sure plugs and jacks are tightly mated. Loose connections can cause hum, noise or intermittents that could easily damage your speakers.
- Never use spray cleaners on the slide controls. Residues cause excessive dirt build-up and this will void your warranty. In normal use slide controls can last for many years. If they malfunction (usually because of a dirty or dusty environment) consult a professional technician.
- Never attempt to make any adjustments or repairs other than those described in this manual. Take the **DM1835X** to your dealer or to an authorized **Numark** Service Center.

A NOTE ON CABLES:

Make the input and output connections with readily available *low-capacitance* stereo cables. Quality cable makes a *big* difference in audio fidelity and punch. Use balanced connections whenever possible. See your **Numark** dealer or an electronics or audio specialist store if you are not sure which cables to get.

SYSTEM PRECAUTIONS

- Use appropriate cables throughout your system: Quality shielded audio cables and terminated shielded video cables, low-capacitance preferred. Speaker cables must be 14-gauge minimum; 12- or 10-gauge is better.
- Reliability will be enhanced through the use of banana connectors on the speaker wires. Observe correct speaker wire polarity. If in doubt, consult your **Numark** dealer or a qualified technician.
- Take care to connect only one cable at a time. Pay attention to the color-coded, labelled Input and Output jacks.
- ALWAYS remember: ***“TURN AMPS ON LAST AND OFF FIRST”***. Begin with master faders or volume controls on minimum and the amplifier gain/input control(s) down. Wait 8 to 10 seconds before turning up the volume. This prevents transients which may cause severe speaker damage.
- Use restraint when operating controls. Try to move them slowly. Rapid adjustments could damage speakers due to amplifier clipping.
- **Avoid amplifier “clipping” at all costs:** this occurs when the red LEDs (usually on the front panel of most professional power amplifiers) start flashing. **“Clipping”** is when the power amplifier is distorting and working beyond it's limits. Amplifier distortion is THE major cause of speaker failure.
- To prevent fire or shock hazard, do not expose the unit to rain or moisture. **Never place cans of beer, soda, glasses of water or anything wet on top of the mixer!**

DM1835X FRONT PANEL DIAGRAM...

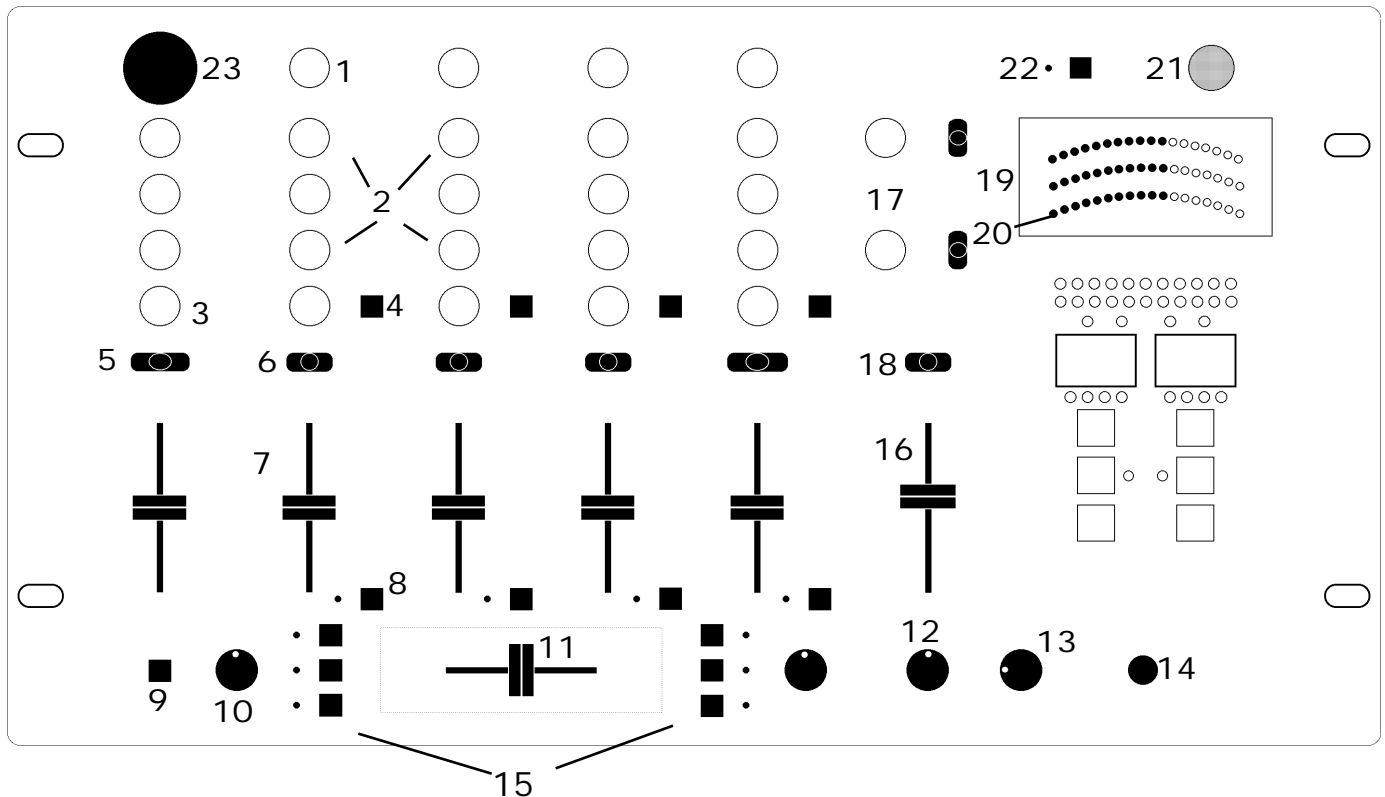

- Channel Input Gain/Trim/Attenuation Controls.**
These control the sensitivity of the inputs for Channels 1-4. Use these whenever a particular source causes overload of the preamp inputs. Attenuation range is 0dB to -20dB. Use these with the PFL (pre-fader listen) monitor when cueing.
- Treble, Middle and Bass Controls** fine tune the tone of your music through the sound system. Note that these are also available on the DJ Mic.
- Use the **Pan Control** to maximize the Left or Right side of your Source.
- Send** button will send the individual channel signal to the send jack on the rear panel. This is used to route to an external effects unit. The signal comes back in from the effects unit through any line input channel you select and is then sent out to your amplifier through the Master Output jacks on the rear panel.
- DJ Mic Talkover Switch** when engaged this mutes your music sources from channels 1-4. Releasing it brings you immediately back to full source level. It is very useful for announcements.
- Channels 1 - 4 Input Toggle Switches** select which source will be live to that channel based on what you have connected to the rear panel input section.
- The **Input Faders** are low-noise, low-impedance, high-quality, smooth faders. These control individual source levels in the mix.
- Channel Cue Assign/PFL** pushbuttons are used to route channel audio to the **Monitor Section**. The channel input faders do not control the **Cue** volume. When the Cue button is pushed you get Pre Fader Listen (PFL). In addition, when these buttons are depressed the third row of the LED meter (20) will display the signal level of that channel on a PFL basis. The level can be adjusted by using the **Gain control** (1).

Numark - The Proven Leader in DJ Technology

9. **The Crossfader In/Out Pushbutton** defeats the entire Crossfader function but leaves the Kill functions active.
10. **Crossfader/Kill Assign Switches** lets you choose which input channel will be heard when the Crossfader is moved to the left or right and affected by the Kill function.
11. The replaceable **Crossfader** achieves clean segues between two selected input channels.

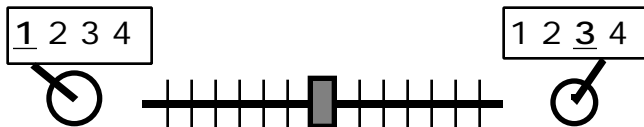

In this example, Channel 1 is selected on the Left and Channel 3 is selected on the Right. With the Crossfader centered both assigned channels are live. Use the Crossfader for fast and seamless segues from one channel to the next.

Note: *the crossfader is user replaceable. Simply unscrew the two large screws which hold it in place, lift it out, and disconnect its cable. Reattach the new crossfader and screw it back onto the unit - you're back in business! REPLACEMENT CROSSFADERS can be purchased from your local Numark Dealer, or by calling Numark Industries.*

12. The **Cue Crossfader** controls what signal is being monitored through your headphones. Move the slide control to the left and you will hear your source music from the channel(s) selected with the cue/PFL switch. Move the control to the right and you will hear your program mix, or output. The slide control allows fast and frequent headphone monitoring.
13. The **Headphone Level** control sets the volume in your headphones.
14. The **Headphone Jack** accepts a 1/4" plug and is set on the front of the unit.
15. **Kill Switches and LEDs** have been provided for Treble, Mid and Bass Control on each side of the crossfader. This allows you to mute that frequency's audio output while leaving the other frequencies playing. This area is always active even when the crossfader is not. *Try that for a neat effect, or mix one channel's treble with another channel's bass (by cutting the mid and bass on the first channel and the treble and mid on the other channel.)*
16. **Master Level.** This controls overall output level. Note that you can select (18) whether you want stereo or mono.
17. The **Zone Levels** control speaker volume for other outputs such as control booth monitors, a tape deck, another amplifier, a sub-woofer, another mixer or a satellite speaker system. Note that you can select (18) whether you want stereo or mono.
- CONTRACTOR'S NOTE:** *Zone Level provides zone control in installations where there are two separate rooms (eg: a bar and a dance floor). The "Zone" volume should be controlled from the mixer not from the amplifier.*
18. The **Stereo/Mono Toggle Switches** allow you to select either stereo or mono output.
19. **Stereo Auto Peak Hold Level Meter.** The red LEDs for +3, +5 and +8dB hold program peaks for an instant. With peak metering, it's OK to be "in the red" as long as +5 or +8dB isn't constantly lit. Set crossover, equalizer and power amplifier inputs to avoid distortion at each step in the audio chain. Proper attention to the peak meters results in the punchiest possible sound without audible distortion.
20. **PFL Meter.** When the Cue/PFL switches are depressed this meter tracks pre-fader listen (PFL) signal for the channel selected instead of the mixer's output level.
21. **12V BNC Connector** allows a 12 volt gooseneck style "Numark" light to be connected directly to the mixer.
22. The **Power button** turns the unit on and off. Make sure your input faders (7) are turned down before you power up your mixer.
23. The **Mic Jack** is a Neutrik™ "Combo Jack" and allows connection of either a 1/4" jack or an XLR jack. This is ideal for connecting an XLR Gooseneck directly.

the **BEATKEEPER** Panel Diagram

A. CHANNEL SELECT-

Tap this button to select desired input channel. The respective input channel LED will light up **1, 2, 3, or 4**

B. SYNC LOCK BUTTON-

When an input is scanning for the correct tempo, tapping the Sync Lock button once will lock in the current BPM as long as there is a BPM number displayed for the input. When an input is locked in tapping the Sync Lock button tells the Beatkeeper to start scanning for a new tempo again.

C. SYNC LOCK LED

OFF- the respective input is not locked or set to track the music

ON- the respective input is synced and ready to track the music

D. BEAT ASSIST BUTTON-

Tapping the Beat Assist button once automatically realigns the downbeat to exactly when you tapped the button. Tapping the beat assist button two or more times also sets the tempo and sync locks the music.

E. BPM DISPLAY-

When no number is displayed the audio signal is still being processed for this input or the Beatkeeper is not receiving any information for this input

(NUMBER DISPLAYED)- The respective input is currently playing music with this number of Beats Per Minute (as determined by the Beatkeeper)

F. DOWN BEAT LED (red)

OFF- the Beatkeeper has not yet matched the beat of the respective audio input

BLINKING- the Beatkeeper has matched this LED to the beat of the respective audio input

ON- the Beatkeeper is waiting for the music to start on the respective input

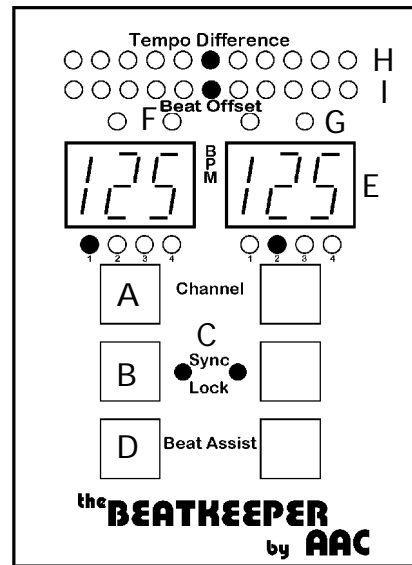

G. PEAK SOUND LED (green)

OFF- the Beatkeeper is not detecting sound from the respective audio input

BLINKING- the Beatkeeper is detecting 'rhythm setting' sounds from the respective audio input

H. TEMPO DIFFERENCE GRAPH

OFF- One or Both of the audio inputs are not yet sync locked in

RED LED ON- The audio inputs tempos are not aligned

YELLOW LED ON- The audio inputs tempos are close to aligned

GREEN LED ON- The audio inputs tempos are perfectly aligned

I. BEAT OFFSET GRAPH

OFF- one or both of the audio inputs are not yet sync locked or are not sending an audio signal

RED LED ON- the audio inputs beats are not aligned

YELLOW LED ON- the audio inputs beats are close to aligned

GREEN LED ON- the audio inputs beats are perfectly aligned

BEATKEEPER OPERATION

Channel Selection

When your mixer is first turned on the channels selected will be 1 & 2 respectively. If you wish to track the beat of another channel, tap on the channel select button until the desired input is reached.

NOTE: The Beatkeeper will track the source that is selected with the channel toggle switch.

Syncing Your Beatkeeper

When learning how to use the Beatkeeper, choose some dance music with a hard, steady beat.

Start the music for left channel of your Beatkeeper. When the Beatkeeper has located the beat, the BPM display will illuminate with the music's Beats Per Minute.

You'll notice a flashing green LED every time the Beatkeeper detects a rhythm defining instrument. The Beatkeeper will soon flash a red LED on every beat, the same way you would tap your foot to the beat of the music. The Beatkeeper will display a BPM which will update every five-seconds while scanning. As long as the beat is well-defined the BPM number will equal the beats per minute of the song being played. **Once you see the red beat LED flashing with the beat of the music, press the respective Sync Lock button,** and the Sync Lock LED will illuminate.

Activating the Sync Lock tells the Beatkeeper to stop scanning the music for a different BPM and to start tracking the beat changes of the current BPM as you adjust the pitch of the music. This function is manual to ensure that the Beatkeeper is right on the beat. **Once the Sync Lock LED is on, the Beatkeeper tracks the beats of the music and updates the BPM display on every beat.**

To unlock, simply tap the Sync Lock button once and the Beatkeeper is back in BPM scanning mode.

After syncing an audio input, try speeding up and slowing down the music. You'll notice that the red beat LED will continue to flash on the downbeat, and the BPM number will adjust itself to match the tempo of the music. This indicates that the Beatkeeper is successfully tracking the beat and will continue to do so throughout your mix. If you stop the music you will notice the Beat LED will go solid and the BPM number will remain in memory. Once the music is restarted the Beatkeeper will remember the last tracked rhythm pattern and pick up on the beat right away.

PLAY the music, **OBSERVE** the beat match, and **PRESS the Sync Lock Button.** That's it. If you can do that twice, you can mix with the Beatkeeper.

Beat Assist

The Beatkeeper is foolproof. The Beatkeeper can track any music up to 199 beats per minute. The unit, however, is set to automatically track tempos between 80-150BPM. Of course not all music is within this range, you may need to track the high tempos of Meringue or Salsa, or the low tempos of R&B slow jams or Reggae. Let's face it, not all music has hard steady beats either and sometimes you just need the music set up yesterday. For these occasions we have the Beat Assist Button.

If the Beatkeeper is having trouble matching the beat to the flashing red Beat LED, or if you need to sync up immediately, tap the Beat Assist button 2-8 times as you hear the beat, the same way you would tap your feet to the music.

Pressing the Beat Assist Button more than once aligns the Beatkeeper to your taps. Notice that the Sync Lock LED automatically illuminates, signifying that the Beatkeeper is now locked in with the beat. Simply put, if the Beatkeeper isn't on track, or you're in a real hurry, you need to press a button twice instead of once.

If the Beatkeeper is synced to the correct BPM but is aligned to the music's offbeat, tap the Beat Assist button with the beat of the music just once and you will have brought the Beatkeeper back in sync.

2 Channel Mixing

After you feel comfortable syncing up the Beatkeeper, you're ready to mix. **Mixing with the Beatkeeper has three parts: syncing to the music** (which you've done), **aligning the tempos, and aligning the beats**. Once these three things are done, you will have a perfect mix. No more guessing, tapping, or embarrassing fades.

Choose another music selection and start it on your right channel. Sync up the first song as described in the last section. With the first selection synced (Sync Lock LED illuminated), **sync up the right channel the same way you set up the left.**

As the second Sync Lock LED illuminates, a new dimension of DJing begins: VISUAL MIXING.

The bar graphs on the top of the Beatkeeper have now been activated and are updating automatically.

NOTE: In order to perform a mix which is tracked by the Beatkeeper, both channels MUST be synced. This is indicated by the yellow Sync Lock LED being lit for both inputs.

In order to create the perfect mix, your goal is to keep both bar graphs as close to centered (green or yellow) as possible.

First, align the top graph, the Tempo Difference Graph. This graph indicates how close the two BPMs are to each other. If they are exactly the same tempo, the green LED in the middle will light up. If one song is faster than the other, the bar graph will shift towards the faster song. **If the Tempo Difference graph is not centered, adjust the speed of one of the inputs using the pitch control.** For example, if the Tempo Difference graph has a red LED illuminated closer to the right channel of the Beatkeeper, the right channel is faster than the left channel, either slow down the right channel, or speed up the left channel.

If the opposite is true, the Tempo Difference Graph has a red LED illuminated on the left channel, indicating the song on the left channel is faster than that the right channel, either slow down the left channel, or speed up the right channel. The second step involves the bottom graph, the Beat Offset Graph. This graph indicates how close the individual beats are. Both BPMs may be the same but the beats may not be in sync. This is often described as the "ping-pong" effect. If the beats are matched, the green LED in the middle lights up. If the beats of one input are earlier than beats of the other input, the Beat Offset Graph will shift toward the song with the earlier beats.

To align the Beat Offset Graph when using CD Players, adjust the appropriate pitch bend. If you are using turntables, hold or apply pressure to the record/turntable and then release to "shift" the beat.

If the Beat Offset graph is shifted toward the right channel either use the minus ("-") pitch bend for the right channel CD player (with vinyl, apply pressure to slow the turntable) or use the plus "+" pitch bend for the left channel CD player (with vinyl push the turntable ahead).

Intuitively, if either bar graph is shifted towards a channel, this indicates that the song on that channel is "ahead" of the other one. Either the tempo is faster (top graph), or the beats come sooner (bottom graph).

When both bar graphs are in the green you are ready to perform your mix!

Don't forget you can always resync to the beat, if it ever shifts off, by tapping the Beat Assist button.

If the beats start to drift, you'll be able to easily adjust the music before your audience can hear it. No other beat counter or automatic mixer can give you the power to make a more accurate mix!

NOTE: The Beat Offset bar graph either indicates beat-to-beat offset, or beat-to-halfbeat offset, whichever is closer. This allows the DJ the option of mixing on the beat or on the half beat.

Multiple Channel Mixing

One exciting feature of your Beatkeeper built into your mixer is the option to visually beat mix more than 2 sources at the same time. Once you have synced a channel of the Beatkeeper the unit will continue to track it even if you should decide to change channels. Up to all four channels can be in sync simultaneously. By selecting different channels you can cross-compare the mix of any 2 channels instantly.

In order to perform a 3-way mix you first will need to set up a 2-way mix as described in the previous section.

NOTE: Multiple source or "layer" mixes should be performed with a minimum of vocals otherwise the music will clash when mixed for a long period of time.

The next step will be to decide which input channel you would like to use as a reference for beat mixing. **While your 2-way mix is ongoing change the channel,** on the side you have **not** chosen as a reference, to the next song you plan to mix into. **Now sync and mix this song like you did for the 2-way mix.** After you have synced up the new song you should continue to check your original mix by switching between channels. When you have properly aligned the new song you are ready to perform a 3-way mix.

To perform a 4-way mix just do the same thing again.

Prepping For A Mix

You may also choose to prep the Beatkeeper for an actual mix. To prep the Beatkeeper, first match the two song's tempos by adjusting the pitch so that the Tempo Difference LED graph displays yellow or green LEDs. Next hit the Cue button of your CD player, or lift your record needle. The red "beat" LED will remain solid alerting you to which input is ready to start. When the music starts again, the Beatkeeper begins right on the beat and indicates how well the two songs are synced within seconds.

Syncing To Off Beats

Now if you really want to be fancy, you can actually use the Beatkeeper to sync to the off-beats. You can have two songs going "Boom - Cha - Boom - Cha". Normally, you would sync the "Booms" of both songs (beat-to-beat mixing). But you can also sync the "Boom" of one song to the "Cha" of the other (beat-to-half beat mixing). The Beatkeeper's Beat Offset graph will display whichever offset is smaller. This allows the DJ the flexibility to mix with the beat or the off-beat.

Beat mixing is a skill that must be practiced in order to be proficient at it. 3 and 4-way mixing can be a very difficult skill to master. Visual mixing with the Beatkeeper gives you the tools to help you do this, but nothing replaces practice.

BEATKEEPER TROUBLESHOOTING

T1 The BPM goes way off when using the search button on my high tech CD mixer.

Some high tech CD mixers have a cueing feature which allows you to cue precisely to an exact spot in the music so you can slam mix. The only problem is that this mode repeats the first beat of the music at a rate which is unrelated to the actual BPM of the music. As a result, the BPM goes off track. The best way to avoid this is to restart the music after a search, make sure the Beatkeeper is resynced to the music and then press the Cue button on the CD player. The Beatkeeper will remember the BPM and track the music once it starts.

T2 The Beatkeeper doesn't resync to the downbeat of the music when the music restarts.

Either the downbeat isn't strong enough to be detected, or the music was started well before a strong downbeat. You can easily resync to the downbeat by tapping the Beat Assist button once with the beat. *Alternatively you can cue the music to a strong downbeat so that the Beatkeeper starts on this downbeat.*

T4 Either the BPM display is blank, or it is noticeably off.

This is common at the beginnings of songs where the beat is not well defined. To sync simply tap the Beat Assist button two or more consecutive times on the downbeat. The Sync Lock LED turns on automatically, indicating that the Beatkeeper is now tracking the beat of the music.

T5 The BPM display is correct, but the beat LED isn't flashing on the downbeats of the music.

If this happens tap the Sync Lock button (turning the Sync Lock LED on) and tap the Beat Assist button once to make the Beatkeeper track the downbeat. You can also use this to force the Beatkeeper to track an offbeat for more advanced mixing.

Alternatively you may sync manually by tapping the Beat Assist button 2 or more times on the beat.

T6 The Beats per minute number seems to jump all over the place.

The Beatkeeper is analyzing different sections of the music to find the BPM. If there is a temporary suspension of a distinct beat or if the rhythm is too complex, this number may not follow the actual BPM.

a) You can wait for a passage of music with a steady beat for a more accurate BPM indication.

b) Hit the Sync Lock button once the red beat LED starts following the beat

or **c)** Tap the Beat Assist button at least twice along with the music beat.

Either method (b or c) will cause the Sync Lock LED to turn and lock on, indicating that the Beatkeeper is now tracking the music.

T7 It takes too long for the Beatkeeper to find the beat on its own.

To speed up the BPM detection process, tap the Beat Assist button at least twice. At this point, the Beatkeeper will turn on the Sync Lock LED, immediately providing a BPM estimate, while resynchronizing to the beat you tapped.

T8 I hit the Sync Lock button, but the flashing red beat LED doesn't seem to follow the beat.

This means you hit the Sync Lock button before the red beat LED actually started tracking the tempo. You can easily fix this by tapping the Beat Assist buttons as many times as necessary to resync to the beat of the music.

T9 The beat tracking suddenly gets off track.

This may happen if the music has several beats missing, or the rhythm suddenly becomes extremely complex or variable. You can either resync the beat using the Beat Assist button or wait a few seconds for the Beatkeeper to automatically recover.

T10 The Beatkeeper seems to track the music for a little bit right after using the Beat Assist, and then drifts off.

This could be one of two things:

a) The Beatkeeper is averaging the time between each of your Beat Assist button taps. If the first tap is way off, the tempo will be way off.

b) The Beatkeeper was synced during a section of the music without a well defined beat.

In either case, the problem can be overcome by waiting a few seconds before preceding to tap the Beat Assist button two or more times with the beat of the music.

T11 Either the BPM number or red beat LED doesn't track the music fast enough while using the pitch bend on my CD player (or speed control on my record player).

You may have exceeded the tracking capability of the Beatkeeper. The Beatkeeper can normally handle speed changes of +/- 5% per beat if the music's rhythm is steady. If the rhythm is complex (or some of the beats are missing) the Beatkeeper will require more gradual changes to track properly.

* If you are using a record player or a wide range pitch bend on a CD player, note that the Beatkeeper only tracks +/- 11.5% from the tempo at which it was synced. You may need to resync the Beatkeeper if you exceed this range while attempting to align tempos.

* *You can also manually resync the beat using the Beat Assist button.*

T12 Neither the Tempo Difference graph or the Beat Offset graph seem to work.

The bar graphs are only operational when both Sync Lock LEDs are illuminated. This ensures that you don't inadvertently try to mix two songs without their tempos being synced.

To make the bar graphs operational, either:

a) Wait for the red beat LED's to follow the music and tap the respective Sync Lock button

or **b)** Tap the Beat Assist button twice with the beat of the music.

Either method will cause the Sync Lock LED to illuminate.

T13 The Beat Offset graph is not illuminated, but the Tempo Difference graph is.

This indicates that one or both of the inputs are not playing. The Beat Offset graph turns off when there are no beats available for tracking on either or both inputs. The graph automatically restarts once both inputs become active again.

T14 The Beat Offset graph has the green LED illuminated when the red beat LEDs are a half beat off from each other.

This indicates that the songs are synced at their half beats. With rap music and some house, mixing is often done on the half beats rather than the down beats themselves. The Beatkeeper intentionally syncs this way to give the DJ the option of beat-to-beat mixing or beat-to-halfbeat mixing

DM1835X REAR PANEL DIAGRAM...

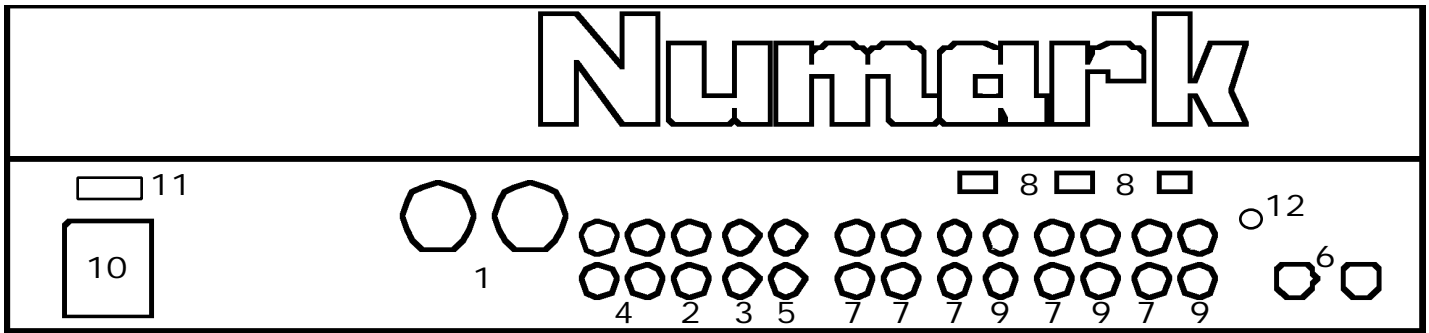

1. The **Balanced Main Outputs** are low-impedance XLR type connectors controlled by the **Master** fader.

2. The **Stereo Main Outputs** are low-impedance RCA connectors controlled by the **Master** fader.

3. The **Tape Outputs** are low-impedance unbalanced RCA jacks which output the program mix and allow you to connect any recording device.

4. The **Stereo Zone Outputs** are low-impedance unbalanced RCA jacks controlled by the **Zone Level** controls.

5. The **Send** can be attached to an external effects processor such as a sampler.

6. **Mic** is the mic input for the Mic Channel and Channel 4.

7. **Channels 1-5 Line Inputs** are unbalanced RCA jacks. The **Line Input** is selected with the toggle switch on the front panel. You can connect stereo audio from HiFi VCRs, cassette and reel-to-reel tape decks, DAT machines, CD players, laser discs, tuners, even synthesizers or other mixing consoles.

NOTE: Plug mono audio sources into both Left and Right inputs using a "Y" cable connector.

8. **Line/Phono Input switch.** Use this to allow line level equipment to be plugged into your phono inputs giving you a total of 8 line input options.

9. **Phono Inputs on Channels 1, 2 and 3** use unbalanced RCA jacks. Your input signal is fed directly to the **DM1835X's** high-quality RIAA phono preamplifiers so use this position only for moving magnet cartridges. Line level sources will overload the sensitive phono preamps and will sound very bad, so always be sure to toggle the line/phono switch over to line before connection of line sources.

10. **AC Cord.** See safety precautions on page 3 for proper treatment of the power cord.

11. **Voltage Selector.** Set this for the appropriate voltage in your area

12. **GND** is the grounding lug for turntables 1, 2 and 3 (phono inputs on Channels 1, 2 and 3). Always use this connection (your turntable cable should have a grounding wire).

DM1835X Instructions for Connection and **DIAGRAM...**

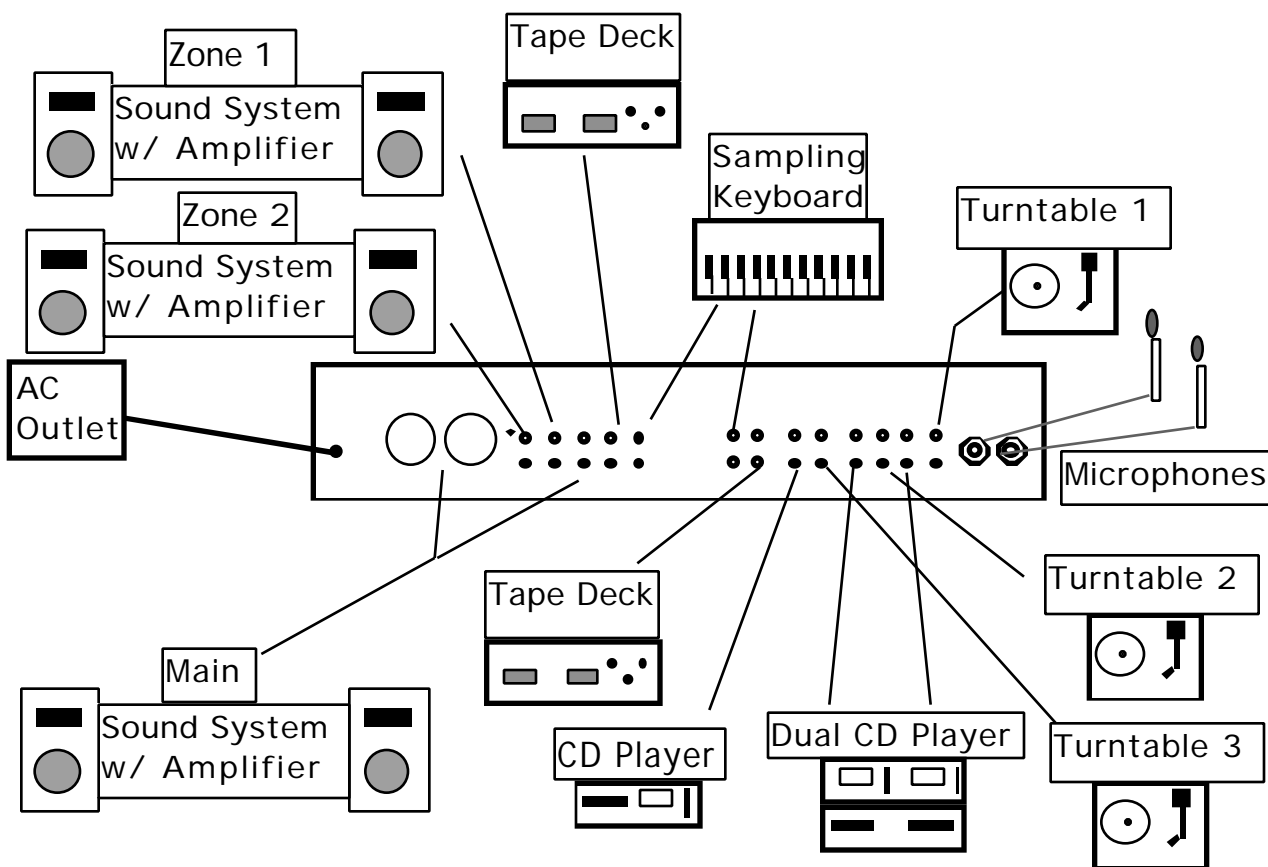

1. Be sure the POWER (22) is OFF. All connections should be made before the unit is turned on. **Always remember "Turn Amps on last and off first!"**
2. Use appropriate cables throughout your system: quality shielded audio cables, low capacitance preferred. Speaker cable must be 14-gauge minimum; 12- or 10-gauge is better.
3. Connect your music sources on the rear of the unit. Up to 3 phono and 8 line sources (CD players, cassette decks, tuners, etc.) can be connected. When connecting to an input with a phono/line option switch remember to set the switch accordingly.
4. Connect the ground wire from your turntables (and any other sources that come with a ground) to the ground post on the rear panel. This will eliminate most common hum and feedback problems.
5. Connect your DJ mic on the front left side of the unit (23) or on the back of the unit at Mic 1. Connect your second mic at Mic 2 on the back of the unit.
6. Connect your headphones on the front right side of the unit at (14).
7. The OUTPUT MASTER jacks on the rear of the unit are for connecting to the amplifier. Use the balanced outputs if possible. Make sure you correctly attach the right and left cables to avoid phasing problems.

Numark - The Proven Leader in DJ Technology

SPECIFICATIONS...

INPUTS:

Line: 10k input impedance
100 mV rms sensitivity (for 1.22 V output)
Mic: 10k input impedance balanced/unbalanced
3 mV rms sensitivity (for 1.22 V output)
50 mV rms max input
Phono:47k input impedance
1.5 mV rms sensitivity @ 1 KHz (for 1.22 V output)

OUTPUTS:

Line: 9V rms max (+20 dBm)
Headphone Amp: 5 watt into 47
Distortion less than .01%

SIGNAL TO NOISE RATIOS

(vs. maximum output):

Line: Better than 82 dB
Mic: Better than 75 dB
Phono:Better than 75 dB

FREQUENCY RESPONSE:

Mic: 20 Hz- 15k Hz \pm .5 dB
Line: 20 Hz- 20k Hz \pm .5 dB
Phono: \pm 1 dB except for controlled attenuation of -3 dB
@ 20 Hz to reduce rumble and feedback

CHANNEL EQ:

Bass: \pm 15db @80Hz
Middle: \pm 10db @1KHz
Treble: \pm 15db @12.5KHz

TALKOVER ATTENUATION:

Variable from no cut to -16 dB

KILL EFFECTS:

Bass: -54dB at 50 Hz, -3dB at 400 Hz
Middle: -44dB at 1k Hz, -3dB at 200Hz
Treble: -53dB at 15k Hz, -3dB at 2k Hz

POWER CONSUMPTION:

20 Watt typical, 28 watt with full headphone output

BEATKEEPER:

Sync Lock Mode

BPM update rate : Every beat
BPM accuracy : \pm 1 BPM
BPM tracking range : 50-199BPM
Bar graph update rate : Every beat
Tempo difference graph resolution:
 \pm 1 BPM per LED, green is \pm 2 BPM
Beat offset graph resolution:
 \pm 7.5msec per LED, green is \pm 15msec

Beat Assist Button

Minimum time between consecutive taps: 0.3 seconds
Maximum time between consecutive taps: 1.2 seconds
Consecutive taps averaging for BPM : Last 2 to 8 taps

BLOCK DIAGRAM...

Numark

Professional Disc Jockey Products

Warranty and Service Information

Numark Industries, LLC and Numark International, Inc. (hereafter "Numark") warrants each new product manufactured and/or supplied by it to be free from defects in material or workmanship under conditions of normal use and service for 360 days, beginning on the date of purchase from an authorized Numark Dealer, but not to exceed 2 years from date of shipment by Numark.

The Numark obligation under this warranty is limited to repairing or replacing, at its option, the product or part(s) therein; which upon examination by Numark shall appear to be defective or not up to factory specifications; providing the Numark product is returned (transportation prepaid) to Numark.

Numark shall not be liable for any damages, consequential or otherwise, resulting from the use and operation of this product and makes no other warranty(s) either express or implied on this product, including any warranty of merchantability.

This warranty does not extend to any of our products which have been subjected to misuse, neglect, accident, incorrect wiring not our own, improper installation, or use in violation of instructions furnished by us, nor extended to units which have been repaired or altered outside of our factory, nor to cases where the serial number thereof has been removed, defaced, or changed, nor to accessories used therewith not of our own manufacture. Numark reserves the right to make changes or improvements in its products, during subsequent production, without incurring the obligation to install such changes or improvements on previously manufactured equipment.

To place this warranty into effect, the enclosed WARRANTY REGISTRATION CARD must be returned to Numark Industries, LLC within thirty (30) days after date of purchase. This warranty gives you specific legal rights, and you may also have other rights which vary from state to state. Some states do not allow the exclusion or limitation of incidental or consequential damages so the above limitation or exclusion may not apply to you.

EQUIPMENT TRANSPORT

A Return Authorization number should be obtained from Numark through the addresses or phone numbers below.

It is the customer's obligation, when returning faulty equipment, to properly pack the Numark equipment in its original packaging. Failure to do so may inadequately protect the equipment in transit and, therefore, jeopardize the customer's warranty. The defective Numark equipment should be sent, FREIGHT PREPAID with Return Authorization number to:

NUMARK INDUSTRIES

**11 Helmsman Road
North Kingstown, RI 02852 USA
Attention: Service Department**

**Telephone: +1 (401) 295-9000
Fax: +1 (401) 295-5200
E-mail: service@numark.com**